

# Introductory Ultimax

## Program Material

Revision 7/93



**HUREO**



®

# **Introductory Ultimax**

## **Program Material**

Revision 7/93

# Ultimax Introductory Program Training Outline

## ***I. Ultimax Control Orientation***

### **A. Machine Operation Features**

1. Tool changer
2. Coolant
3. Spindle
4. Start/Motion hold
5. System modes

- a. Manual
- b. Test
- c. Single
- d. Auto

6. Function keys
7. Jog/override

### **B. Program Mode Features**

1. Input
2. Review
3. Auxiliary
4. Help
5. Calculator
6. Enter/Back/Advance
7. Clear

## ***II. Programming Orientation***

### **A. Part Setup**

1. Part zero
2. "Z" offset
3. Safety work regions

### **B. Tool Setup**

1. Tool in spindle
2. Description
3. Calibration
4. Surface feed (SFM)
5. Chip load

### **C. Program Parameters**

1. General parameters
2. Holes parameters
3. Milling parameters
4. Program parameters

### **D. Part Programming**

1. Block structure
  - a. Blocks
  - b. Operations
  - c. Segments
2. Types of blocks
  - a. Position
  - b. Holes
  - c. Milling
  - d. Patterns
  - e. Miscellaneous
  - f. Special

## ***III. Program Examples***

- A. Use of Example Prints
- B. Purpose
- C. Defining Datum Lines
- D. Selecting Tools

## ***IV. Simple Milling***

- A. Circle
- B. Frame
- C. Ellipse
- D. Blend Offset/Overlap

## ***V. Holes***

- A. Drill Operations
- B. Bore/Ream Operations
- C. Tapping Operations
- D. Bolt Circle
- E. Locations

## ***VI. Contour Milling***

### **A. Lines and Arcs**

1. Lines
2. Arcs
3. Blend arcs
4. Helix
5. 3D arc

### **B. Pocketing**

1. Start points
2. Closed contour
3. Maximum offset

## ***VII. Patterns***

- A. Loop Rectangular
- B. Loop Linear
- C. Loop Angular
- D. Loop Rotate
- E. Pattern Locations
- F. Scale
- G. Mirror Image
- H. Pattern End
- I. Nesting Patterns

## ***VIII. Auxiliary Mode***

- A. Storage Functions
- B. Upload/Download
- C. Change Executive
- D. Reset Master

## ***IX. Test***

- A. Check for Errors
- B. Dry Run

REV. B

INTRO-2

1 of 1

REV.

PROPRIETARY INFORMATION

Information contained herein is the property of Hurco Manufacturing Company, Inc. No reproduction or disclosure of this information shall be made by any person in any form or by any means without the prior written consent of Hurco Manufacturing Company, Inc.

TOOL LIST

3/4 CENTER CUT END MILL

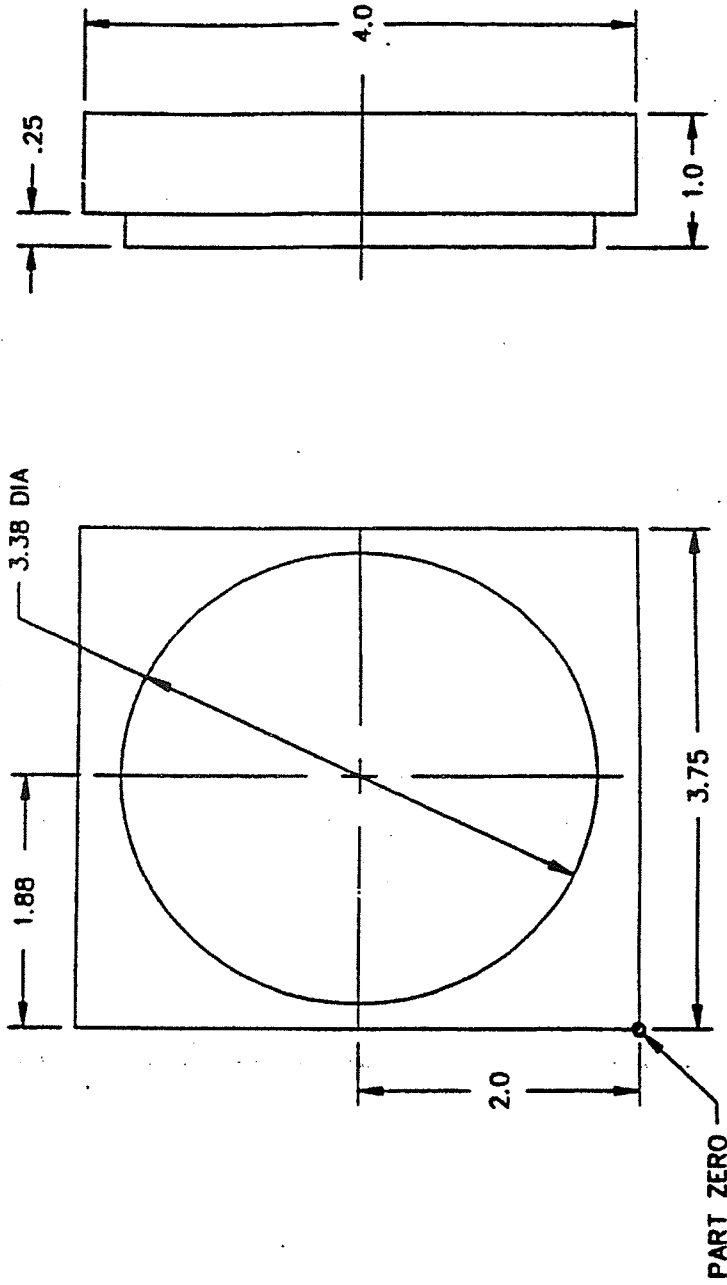

SURFACE TREATMENT		1" X 3 3/4" X 4" 1045 C.R.S.		MURCO MANUFACTURING COMPANY, INC. WINDYBROOK, IN U.S.A.	
2	2	DMK	DMK	DMK	DMK
PLUG 1		DMK	DMK	DMK	DMK
M-8		DMK	DMK	DMK	DMK
INTRO-2		DMK	DMK	DMK	DMK

CN I 02



SIZE **B**

INTRO-4

REV. 1

**PROPRIETARY INFORMATION**

INFORMATION CONTAINED HEREIN IS THE PROPERTY OF HURCO MANUFACTURING COMPANY, INC. NO REPRODUCTION OR DISCLOSURE OF THIS INFORMATION SHALL BE MADE BY THE RECIPIENT TO ANY OTHER PERSON OR ORGANIZATION WITHOUT THE WRITTEN PERMISSION OF HURCO MANUFACTURING COMPANY, INC.

**TOOL LIST**

**11/16 CENTER CUT END MILL**

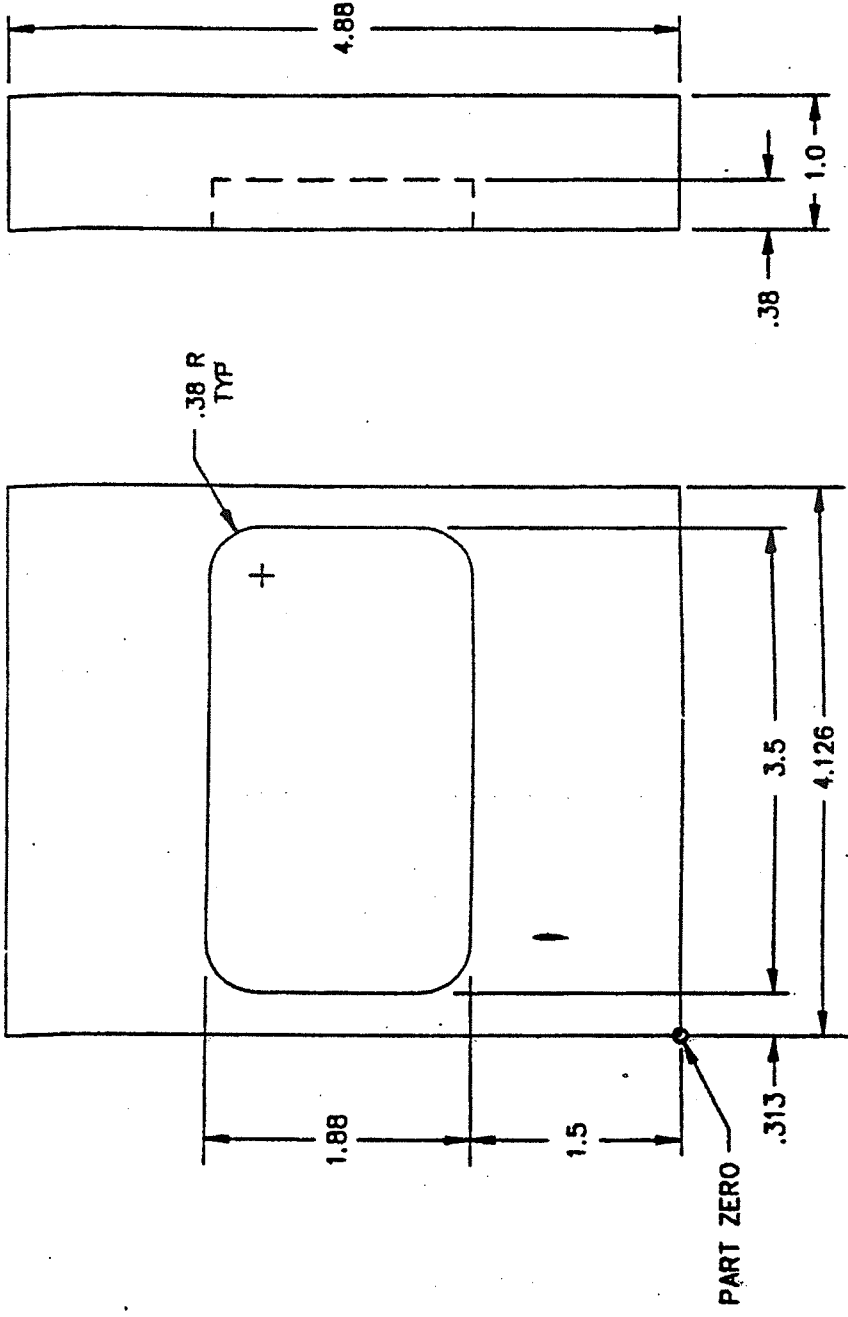

1 X 4.126 X 4.875 CARBON STEEL		HURCO		HURCO MANUFACTURING COMPANY, INC. INDIANAPOLIS, IN U.S.A.	
EXCEPT AS NOTED ALL DIMENSIONS IN THIS DRAWING ARE UNLESS OTHERWISE SPECIFIED	DESCRIPTION <b>CUSHION 1</b>	DATE 9-4-83	BY R.HALL	PROJECT 5-24-83	DATE 5-24-83
SURFACE TREATMENT ~	FINISH ~	SCALE 1:1	QUANTITY 1	ORDER NO. INTRO-4	REV. 1
THIS TOOL IS M-8	PRODUCTION EA	DATE 9-4-83	BY R.HALL	PROJECT 5-24-83	DATE 5-24-83

CN  
I 04

REV	CHG	INTRO-5	REV	1	1
B				1	1

PROPRIETARY INFORMATION  
 INFORMATION CONTAINED HEREIN IS THE PROPERTY OF HURCO MANUFACTURING COMPANY, INC. NO REPRODUCTION OR  
 DISCLOSURE OF THIS INFORMATION SHALL BE MADE BY ANY PERSON IN ANY MANNER WITHOUT THE WRITTEN CONSENT OF HURCO MANUFACTURING COMPANY, INC.

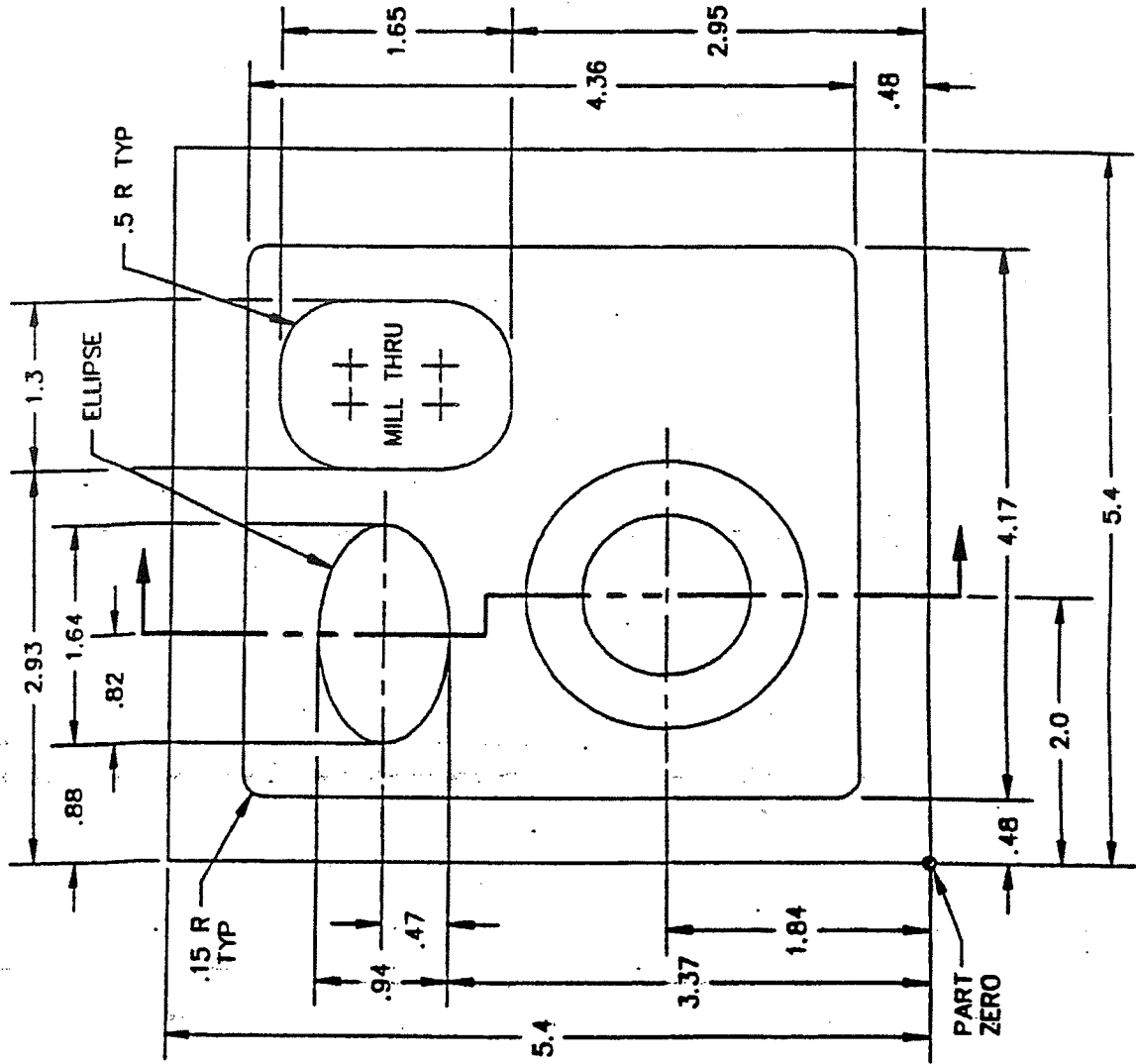

TOOL LIST

3/4 CENTER CUT END MILL  
 1/2 CENTER CUT END MILL

SURFACE TREATMENT		.69 X 5.4 X 5.4 5056 ALUMINUM	
MATERIAL		HURCO	
DESCRIPTION		CUSHION 1	
QTY	DATE	QTY	DATE
2	2-4-83	2	5-28-83
DMK	R.HALL	APPROV	R.HALL
SCALE	1-1	DATE	5-28-83
PROJ	B	REV	1
TITLE	INTRO-5	REV	1

CN  
I 05

REV. 1  
 1  
 of 1

PROPRIETARY INFORMATION  
 INFORMATION CONTAINED HEREIN IS THE PROPERTY OF HURCO MANUFACTURING COMPANY, INC. NO REPRODUCTION OR  
 DISCLOSURE OF THIS INFORMATION SHALL BE MADE BY ANY OTHER PERSON OR ORGANIZATION WITHOUT  
 THE EXPRESS WRITTEN CONSENT OF HURCO MANUFACTURING COMPANY, INC.

**TOOL LIST**  
**1/8 CENTER DRILL**  
**3/8 DRILL**

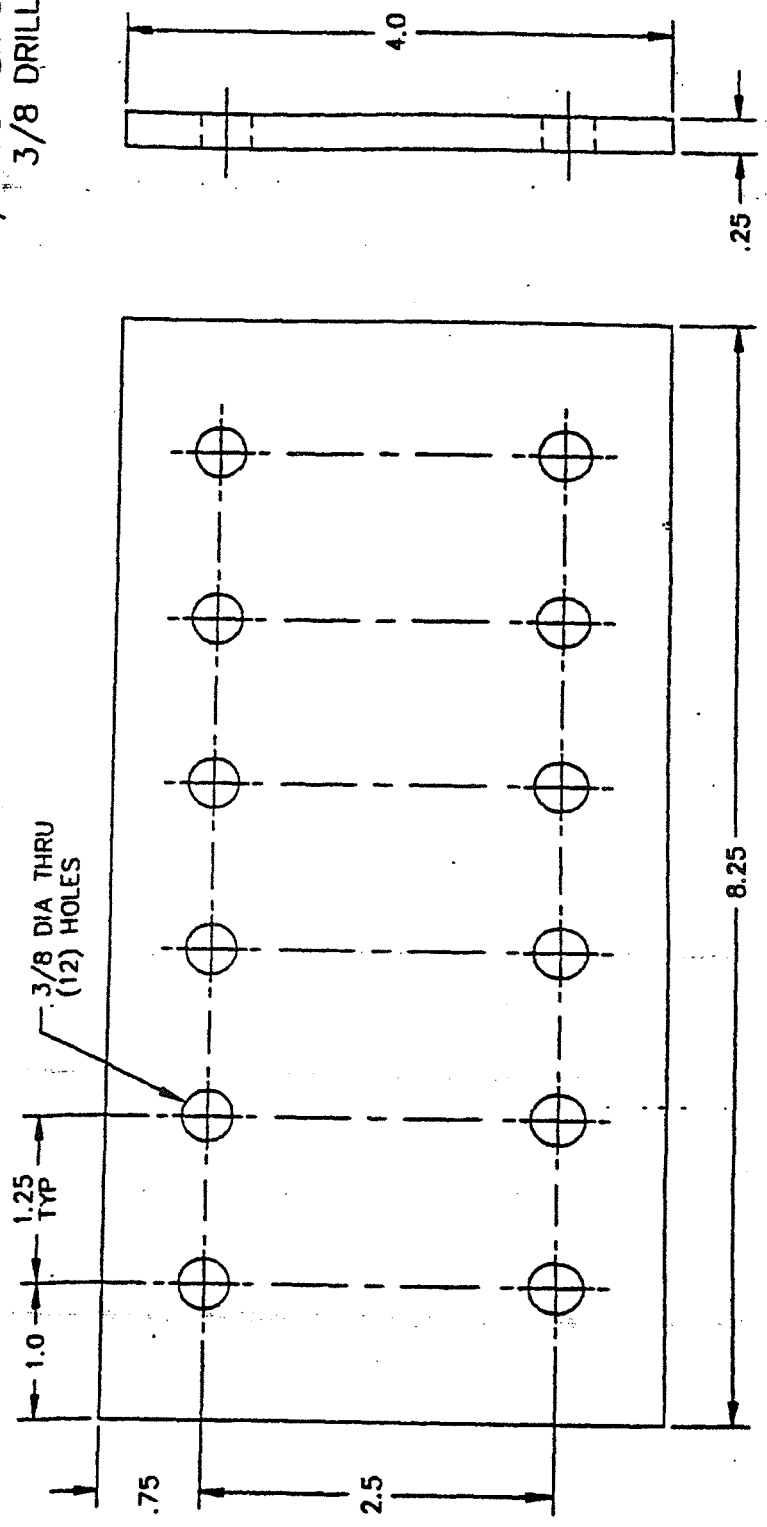

PART NUMBER		ITEM DESCRIPTION		PARTS LIST	
.25 X 4.0 X 8.0 6061 ALUMINUM					
SURFACE TREATMENT		CHECK IN ORDER ALL DIMENSIONS IN INCHES UNLESS OTHERWISE SPECIFIED		REVISION	
M-8		A 1.000 B 1.000 C 1.000 D 1.000 E 1.000 F 1.000 G 1.000 H 1.000 I 1.000 J 1.000 K 1.000 L 1.000 M 1.000 N 1.000 O 1.000 P 1.000 Q 1.000 R 1.000 S 1.000 T 1.000 U 1.000 V 1.000 W 1.000 X 1.000 Y 1.000 Z 1.000		DATE REVISION 8-4-93 R.HALL 8-4-93 GAW 8-4-93 8-4-93	
MATERIAL		PLATE, SPACER		HURCO MANUFACTURING COMPANY, INC. HOUSTON, TX U.S.A.	
M-8		EA		INTRO-8	

CN  
 I08







**REV** **QTY** **REV**  
**B** **INTRO-13** **1** **1**  
 PROPRIETARY INFORMATION  
 INFORMATION CONTAINED HEREIN IS THE PROPERTY OF HURCO MANUFACTURING COMPANY, INC. NO REPRODUCTION OR  
 DISCLOSURE OF THIS INFORMATION SHALL BE MADE BY ANY PERSON TO ANY OTHER PERSON OR ORGANIZATION WITHOUT  
 THE EXPRESS WRITTEN CONSENT OF HURCO MANUFACTURING COMPANY, INC.

**TOOL LIST**  
**3/4 CENTER CUT END MILL**

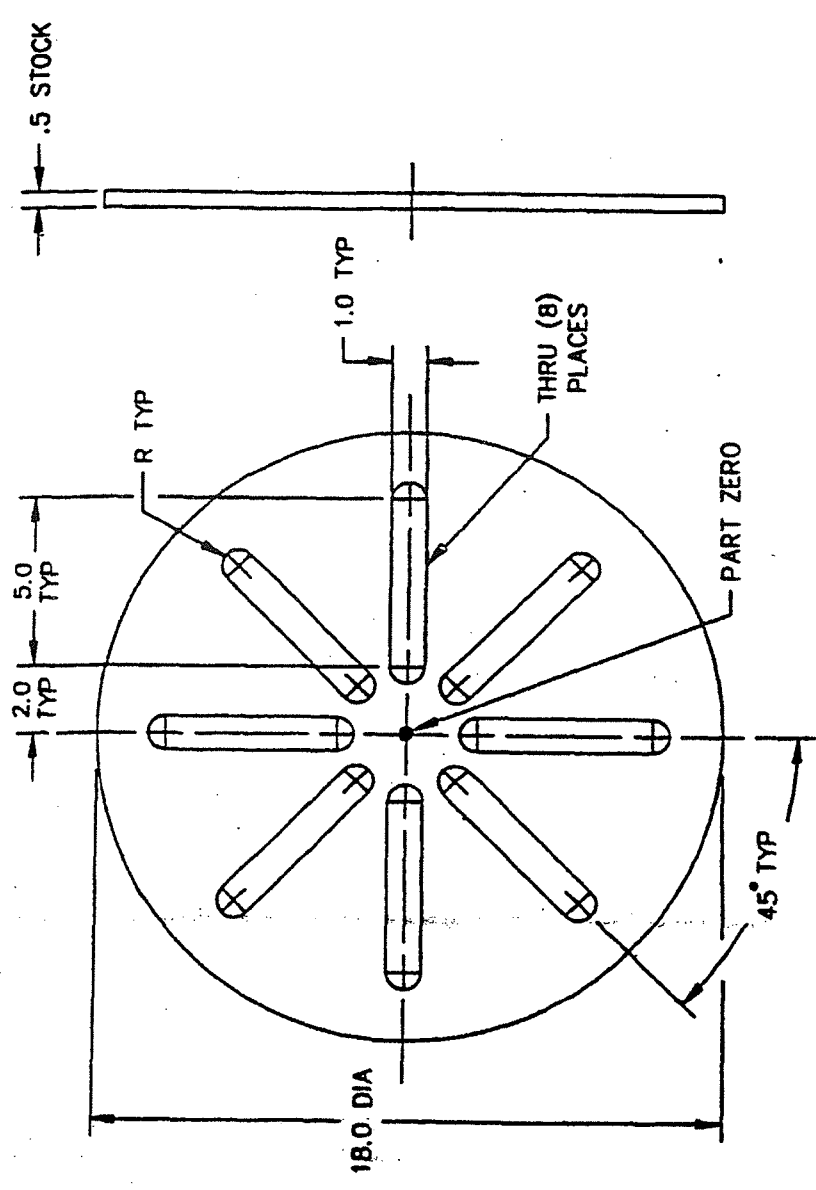

QTY	PART NUMBER	ITEM DESCRIPTION	REV
		.5 X 18.0 DIA BAR 6262-78511 ALUMINUM	
SURFACE FINISH:		EXCEPT AS NOTED ALL DIMENSIONS IN THIS DRAWING UNLESS OTHERWISE SPECIFIED ARE TO BE HOLD TO TYPICAL TOLERANCES UNLESS OTHERWISE SPECIFIED DIMENSIONS IN PARENTHESES ARE TO BE HOLD TO TYPICAL TOLERANCES UNLESS OTHERWISE SPECIFIED	DATE 8-8-83 BY R. HALL CHECKED 8-8-83 DATE 8-8-83 APPROVED GAW DATE 8-8-83 BY
2			
2			
M-8			
TABLE, INDEX		HURCO HURCO MANUFACTURING COMPANY, INC. MOBILE, AL, U.S.A.	
DESCRIPTION		TABLE, INDEX DATE 8-8-83 BY R. HALL CHECKED 8-8-83 DATE 8-8-83 APPROVED GAW DATE 8-8-83 BY	
PART LIST		B INTRO-13	

**CN**  
**I13**



DATE **B**  
 DRAWING **INTRO-18**

SHEET **1**  
 OF **1**

PROPRIETARY INFORMATION  
 INFORMATION CONTAINED HEREIN IS THE PROPERTY OF HURCO MANUFACTURING COMPANY, INC. NO REPRODUCTION OR  
 DISCLOSURE OF THIS INFORMATION SHALL BE MADE BY ANY PERSON IN ANY MANNER WITHOUT THE WRITTEN  
 CONSENT OF HURCO MANUFACTURING COMPANY, INC.

**TOOL LIST**  
**3/4 END MILL**

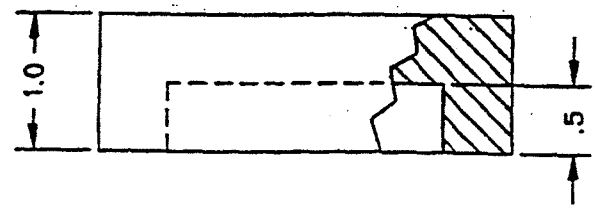
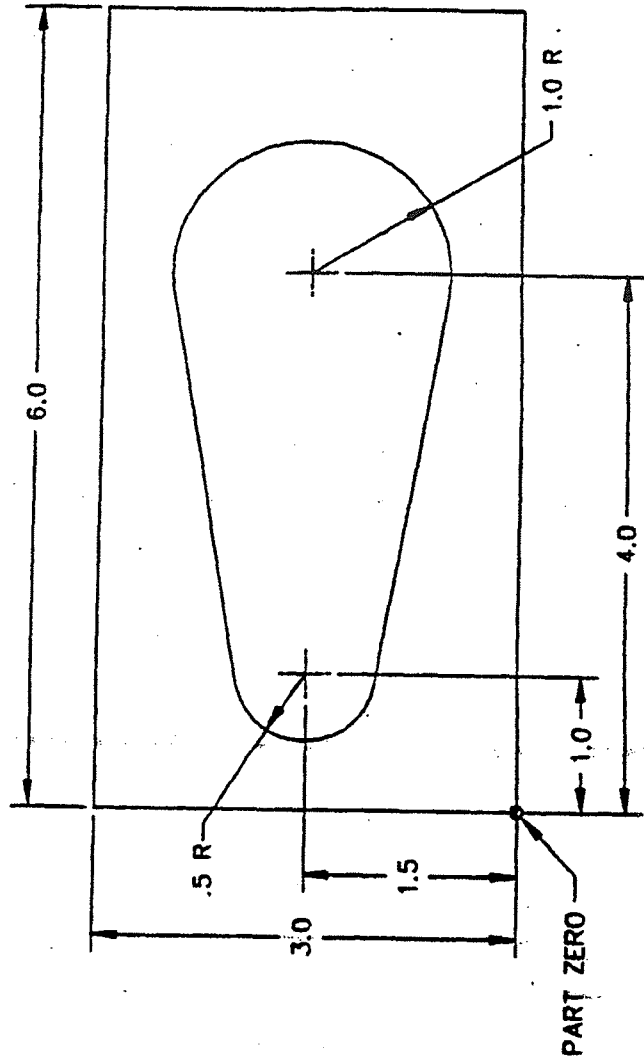

1.0 X 3.0 X 6.0 ASTM A36 CRS		PART NUMBER		FOR DESCRIPTION		REV	
SURFACE TREATMENT		CHECK IN WHICH ALL DIMENSIONS IN HOOKS & GROOVES SHALL BE TO UNLESS OTHERWISE SPECIFIED		REVISION		DATE	
~		A		1		8-4-93	
~		B		2		8-4-93	
PART USED BY		M-8		INTRO-18		DATE	
MURCO		MURCO MANUFACTURING COMPANY, INC.		INDIANAPOLIS, IN U.S.A.		DATE	
PLATE, LOWER LOCK		GLH		R.HALL		8-4-93	
1 = 1		EA.		INTRO-18		DATE	
M-8		INTRO-18		INTRO-18		DATE	

CN  
 T1R





SIZE **B** DRAWING **INTRO-21** REV. **1**

**PROPRIETARY INFORMATION**  
 INFORMATION CONTAINED HEREIN IS THE PROPERTY OF HURCO MANUFACTURING COMPANY, INC. NO REPRODUCTION OR DISCLOSURE OF THIS INFORMATION SHALL BE MADE BY THE RECIPIENT TO ANY OTHER PERSON OR ORGANIZATION WITHOUT THE PRIOR WRITTEN CONSENT OF HURCO MANUFACTURING COMPANY, INC.

**TOOLS**

1/8 Center Drill  
 1/2 Drill  
 5/8 End Mill

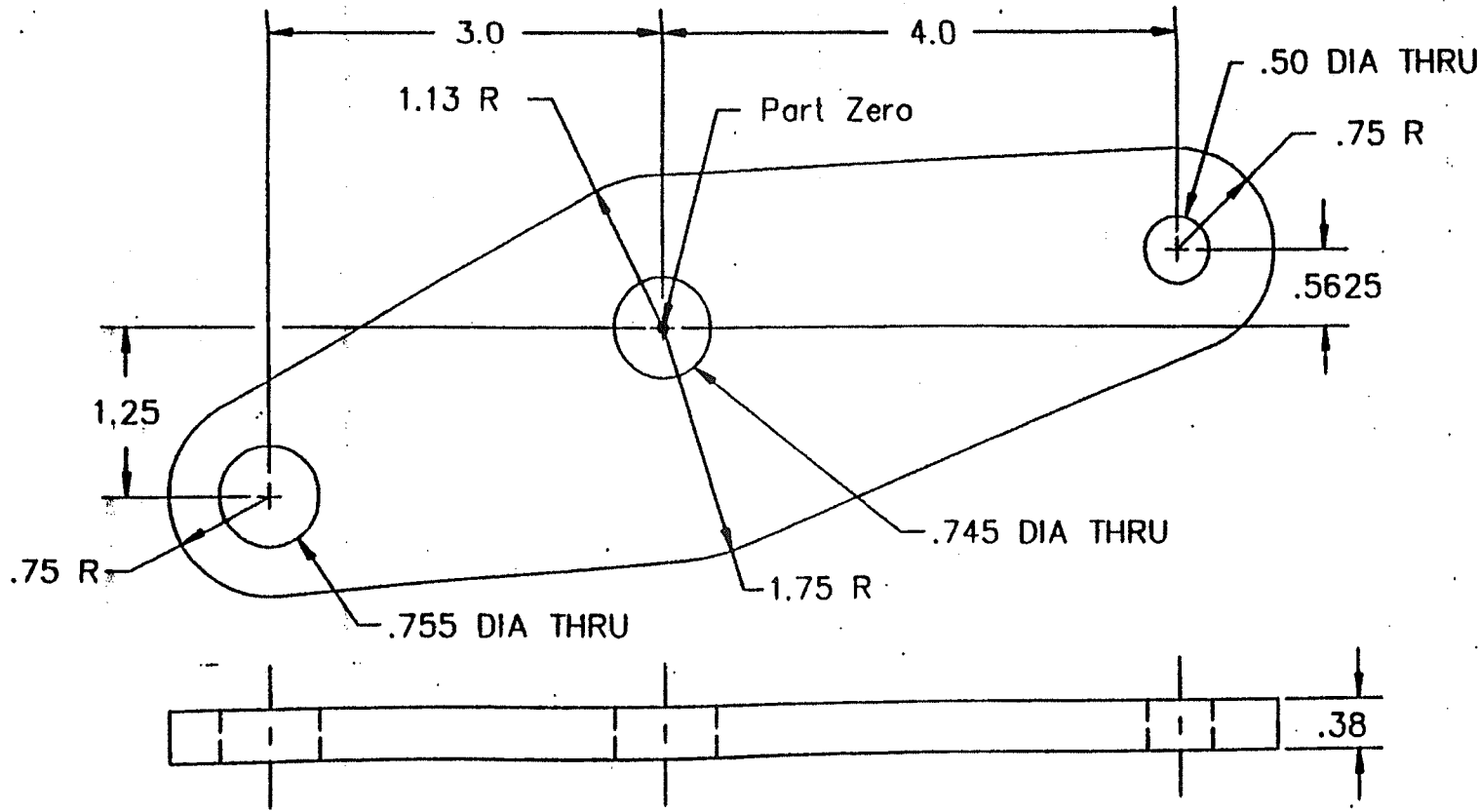

CN  
 I 21

3/8 THICK CLASS 45 CAST IRON							
SURFACE TREATMENT ~		EXCEPT AS NOTED: ALL DIMENSIONS IN INCHES TOLERANCE		 <b>HURCO MANUFACTURING COMPANY, INC.</b> INDIANAPOLIS, IN U.S.A.			
HEAD TREATMENT ~		DECIMAL .0001 0.0000 .0002 0.0001 .0003 0.0002 .0004 0.0003 .0005 0.0004 .0006 0.0005 .0007 0.0006 .0008 0.0007 .0009 0.0008 .0010 0.0009 .0011 0.0010 .0012 0.0011 .0013 0.0012 .0014 0.0013 .0015 0.0014 .0016 0.0015 .0017 0.0016 .0018 0.0017 .0019 0.0018 .0020 0.0019 .0021 0.0020 .0022 0.0021 .0023 0.0022 .0024 0.0023 .0025 0.0024 .0026 0.0025 .0027 0.0026 .0028 0.0027 .0029 0.0028 .0030 0.0029 .0031 0.0030 .0032 0.0031 .0033 0.0032 .0034 0.0033 .0035 0.0034 .0036 0.0035 .0037 0.0036 .0038 0.0037 .0039 0.0038 .0040 0.0039 .0041 0.0040 .0042 0.0041 .0043 0.0042 .0044 0.0043 .0045 0.0044 .0046 0.0045 .0047 0.0046 .0048 0.0047 .0049 0.0048 .0050 0.0049 .0051 0.0050 .0052 0.0051 .0053 0.0052 .0054 0.0053 .0055 0.0054 .0056 0.0055 .0057 0.0056 .0058 0.0057 .0059 0.0058 .0060 0.0059 .0061 0.0060 .0062 0.0061 .0063 0.0062 .0064 0.0063 .0065 0.0064 .0066 0.0065 .0067 0.0066 .0068 0.0067 .0069 0.0068 .0070 0.0069 .0071 0.0070 .0072 0.0071 .0073 0.0072 .0074 0.0073 .0075 0.0074 .0076 0.0075 .0077 0.0076 .0078 0.0077 .0079 0.0078 .0080 0.0079 .0081 0.0080 .0082 0.0081 .0083 0.0082 .0084 0.0083 .0085 0.0084 .0086 0.0085 .0087 0.0086 .0088 0.0087 .0089 0.0088 .0090 0.0089 .0091 0.0090 .0092 0.0091 .0093 0.0092 .0094 0.0093 .0095 0.0094 .0096 0.0095 .0097 0.0096 .0098 0.0097 .0099 0.0098 .0100 0.0099 .0101 0.0100 .0102 0.0101 .0103 0.0102 .0104 0.0103 .0105 0.0104 .0106 0.0105 .0107 0.0106 .0108 0.0107 .0109 0.0108 .0110 0.0109 .0111 0.0110 .0112 0.0111 .0113 0.0112 .0114 0.0113 .0115 0.0114 .0116 0.0115 .0117 0.0116 .0118 0.0117 .0119 0.0118 .0120 0.0119 .0121 0.0120 .0122 0.0121 .0123 0.0122 .0124 0.0123 .0125 0.0124 .0126 0.0125 .0127 0.0126 .0128 0.0127 .0129 0.0128 .0130 0.0129 .0131 0.0130 .0132 0.0131 .0133 0.0132 .0134 0.0133 .0135 0.0134 .0136 0.0135 .0137 0.0136 .0138 0.0137 .0139 0.0138 .0140 0.0139 .0141 0.0140 .0142 0.0141 .0143 0.0142 .0144 0.0143 .0145 0.0144 .0146 0.0145 .0147 0.0146 .0148 0.0147 .0149 0.0148 .0150 0.0149 .0151 0.0150 .0152 0.0151 .0153 0.0152 .0154 0.0153 .0155 0.0154 .0156 0.0155 .0157 0.0156 .0158 0.0157 .0159 0.0158 .0160 0.0159 .0161 0.0160 .0162 0.0161 .0163 0.0162 .0164 0.0163 .0165 0.0164 .0166 0.0165 .0167 0.0166 .0168 0.0167 .0169 0.0168 .0170 0.0169 .0171 0.0170 .0172 0.0171 .0173 0.0172 .0174 0.0173 .0175 0.0174 .0176 0.0175 .0177 0.0176 .0178 0.0177 .0179 0.0178 .0180 0.0179 .0181 0.0180 .0182 0.0181 .0183 0.0182 .0184 0.0183 .0185 0.0184 .0186 0.0185 .0187 0.0186 .0188 0.0187 .0189 0.0188 .0190 0.0189 .0191 0.0190 .0192 0.0191 .0193 0.0192 .0194 0.0193 .0195 0.0194 .0196 0.0195 .0197 0.0196 .0198 0.0197 .0199 0.0198 .0200 0.0199 .0201 0.0200 .0202 0.0201 .0203 0.0202 .0204 0.0203 .0205 0.0204 .0206 0.0205 .0207 0.0206 .0208 0.0207 .0209 0.0208 .0210 0.0209 .0211 0.0210 .0212 0.0211 .0213 0.0212 .0214 0.0213 .0215 0.0214 .0216 0.0215 .0217 0.0216 .0218 0.0217 .0219 0.0218 .0220 0.0219 .0221 0.0220 .0222 0.0221 .0223 0.0222 .0224 0.0223 .0225 0.0224 .0226 0.0225 .0227 0.0226 .0228 0.0227 .0229 0.0228 .0230 0.0229 .0231 0.0230 .0232 0.0231 .0233 0.0232 .0234 0.0233 .0235 0.0234 .0236 0.0235 .0237 0.0236 .0238 0.0237 .0239 0.0238 .0240 0.0239 .0241 0.0240 .0242 0.0241 .0243 0.0242 .0244 0.0243 .0245 0.0244 .0246 0.0245 .0247 0.0246 .0248 0.0247 .0249 0.0248 .0250 0.0249 .0251 0.0250 .0252 0.0251 .0253 0.0252 .0254 0.0253 .0255 0.0254 .0256 0.0255 .0257 0.0256 .0258 0.0257 .0259 0.0258 .0260 0.0259 .0261 0.0260 .0262 0.0261 .0263 0.0262 .0264 0.0263 .0265 0.0264 .0266 0.0265 .0267 0.0266 .0268 0.0267 .0269 0.0268 .0270 0.0269 .0271 0.0270 .0272 0.0271 .0273 0.0272 .0274 0.0273 .0275 0.0274 .0276 0.0275 .0277 0.0276 .0278 0.0277 .0279 0.0278 .0280 0.0279 .0281 0.0280 .0282 0.0281 .0283 0.0282 .0284 0.0283 .0285 0.0284 .0286 0.0285 .0287 0.0286 .0288 0.0287 .0289 0.0288 .0290 0.0289 .0291 0.0290 .0292 0.0291 .0293 0.0292 .0294 0.0293 .0295 0.0294 .0296 0.0295 .0297 0.0296 .0298 0.0297 .0299 0.0298 .0300 0.0299 .0301 0.0300 .0302 0.0301 .0303 0.0302 .0304 0.0303 .0305 0.0304 .0306 0.0305 .0307 0.0306 .0308 0.0307 .0309 0.0308 .0310 0.0309 .0311 0.0310 .0312 0.0311 .0313 0.0312 .0314 0.0313 .0315 0.0314 .0316 0.0315 .0317 0.0316 .0318 0.0317 .0319 0.0318 .0320 0.0319 .0321 0.0320 .0322 0.0321 .0323 0.0322 .0324 0.0323 .0325 0.0324 .0326 0.0325 .0327 0.0326 .0328 0.0327 .0329 0.0328 .0330 0.0329 .0331 0.0330 .0332 0.0331 .0333 0.0332 .0334 0.0333 .0335 0.0334 .0336 0.0335 .0337 0.0336 .0338 0.0337 .0339 0.0338 .0340 0.0339 .0341 0.0340 .0342 0.0341 .0343 0.0342 .0344 0.0343 .0345 0.0344 .0346 0.0345 .0347 0.0346 .0348 0.0347 .0349 0.0348 .0350 0.0349 .0351 0.0350 .0352 0.0351 .0353 0.0352 .0354 0.0353 .0355 0.0354 .0356 0.0355 .0357 0.0356 .0358 0.0357 .0359 0.0358 .0360 0.0359 .0361 0.0360 .0362 0.0361 .0363 0.0362 .0364 0.0363 .0365 0.0364 .0366 0.0365 .0367 0.0366 .0368 0.0367 .0369 0.0368 .0370 0.0369 .0371 0.0370 .0372 0.0371 .0373 0.0372 .0374 0.0373 .0375 0.0374 .0376 0.0375 .0377 0.0376 .0378 0.0377 .0379 0.0378 .0380 0.0379 .0381 0.0380 .0382 0.0381 .0383 0.0382 .0384 0.0383 .0385 0.0384 .0386 0.0385 .0387 0.0386 .0388 0.0387 .0389 0.0388 .0390 0.0389 .0391 0.0390 .0392 0.0391 .0393 0.0392 .0394 0.0393 .0395 0.0394 .0396 0.0395 .0397 0.0396 .0398 0.0397 .0399 0.0398 .0400 0.0399 .0401 0.0400 .0402 0.0401 .0403 0.0402 .0404 0.0403 .0405 0.0404 .0406 0.0405 .0407 0.0406 .0408 0.0407 .0409 0.0408 .0410 0.0409 .0411 0.0410 .0412 0.0411 .0413 0.0412 .0414 0.0413 .0415 0.0414 .0416 0.0415 .0417 0.0416 .0418 0.0417 .0419 0.0418 .0420 0.0419 .0421 0.0420 .0422 0.0421 .0423 0.0422 .0424 0.0423 .0425 0.0424 .0426 0.0425 .0427 0.0426 .0428 0.0427 .0429 0.0428 .0430 0.0429 .0431 0.0430 .0432 0.0431 .0433 0.0432 .0434 0.0433 .0435 0.0434 .0436 0.0435 .0437 0.0436 .0438 0.0437 .0439 0.0438 .0440 0.0439 .0441 0.0440 .0442 0.0441 .0443 0.0442 .0444 0.0443 .0445 0.0444 .0446 0.0445 .0447 0.0446 .0448 0.0447 .0449 0.0448 .0450 0.0449 .0451 0.0450 .0452 0.0451 .0453 0.0452 .0454 0.0453 .0455 0.0454 .0456 0.0455 .0457 0.0456 .0458 0.0457 .0459 0.0458 .0460 0.0459 .0461 0.0460 .0462 0.0461 .0463 0.0462 .0464 0.0463 .0465 0.0464 .0466 0.0465 .0467 0.0466 .0468 0.0467 .0469 0.0468 .0470 0.0469 .0471 0.0470 .0472 0.0471 .0473 0.0472 .0474 0.0473 .0475 0.0474 .0476 0.0475 .0477 0.0476 .0478 0.0477 .0479 0.0478 .0480 0.0479 .0481 0.0480 .0482 0.0481 .0483 0.0482 .0484 0.0483 .0485 0.0484 .0486 0.0485 .0487 0.0486 .0488 0.0487 .0489 0.0488 .0490 0.0489 .0491 0.0490 .0492 0.0491 .0493 0.0492 .0494 0.0493 .0495 0.0494 .0496 0.0495 .0497 0.0496 .0498 0.0497 .0499 0.0498 .0500 0.0499 .0501 0.0500 .0502 0.0501 .0503 0.0502 .0504 0.0503 .0505 0.0504 .0506 0.0505 .0507 0.0506 .0508 0.0507 .0509 0.0508 .0510 0.0509 .0511 0.0510 .0512 0.0511 .0513 0.0512 .0514 0.0513 .0515 0.0514 .0516 0.0515 .0517 0.0516 .0518 0.0517 .0519 0.0518 .0520 0.0519 .0521 0.0520 .0522 0.0521 .0523 0.0522 .0524 0.0523 .0525 0.0524 .0526 0.0525 .0527 0.0526 .0528 0.0527 .0529 0.0528 .0530 0.0529 .0531 0.0530 .0532 0.0531 .0533 0.0532 .0534 0.0533 .0535 0.0534 .0536 0.0535 .0537 0.0536 .0538 0.0537 .0539 0.0538 .0540 0.0539 .0541 0.0540 .0542 0.0541 .0543 0.0542 .0544 0.0543 .0545 0.0544 .0546 0.0545 .0547 0.0546 .0548 0.0547 .0549 0.0548 .0550 0.0549 .0551 0.0550 .0552 0.0551 .0553 0.0552 .0554 0.0553 .0555 0.0554 .0556 0.0555 .0557 0.0556 .0558 0.0557 .0559 0.0558 .0560 0.0559 .0561 0.0560 .0562 0.0561 .0563 0.0562 .0564 0.0563 .0565 0.0564 .0566 0.0565 .0567 0.0566 .0568 0.0567 .0569 0.0568 .0570 0.0569 .0571 0.0570 .0572 0.0571 .0573 0.0572 .0574 0.0573 .0575 0.0574 .0576 0.0575 .0577 0.0576 .0578 0.0577 .0579 0.0578 .0580 0.0579 .0581 0.0580 .0582 0.0581 .0583 0.0582 .0584 0.0583 .0585 0.0584 .0586 0.0585 .0587 0.0586 .0588 0.0587 .0589 0.0588 .0590 0.0589 .0591 0.0590 .0592 0.0591 .0593 0.0592 .0594 0.0593 .0595 0.0594 .0596 0.0595 .0597 0.0596 .0598 0.0597 .0599 0.0598 .0600 0.0599 .0601 0.0600 .0602 0.0601 .0603 0.0602 .0604 0.0603 .0605 0.0604 .0606 0.0605 .0607 0.0606 .0608 0.0607 .0609 0.0608 .0610 0.0609 .0611 0.0610 .0612 0.0611 .0613 0.0612 .0614 0.0613 .0615 0.0614 .0616 0.0615 .0617 0.0616 .0618 0.0617 .0619 0.0618 .0620 0.0619 .0621 0.0620 .0622 0.0621 .0623 0.0622 .0624 0.0623 .0625 0.0624 .0626 0.0625 .0627 0.0626 .0628 0.0627 .0629 0.0628 .0630 0.0629 .0631 0.0630 .0632 0.0631 .0633 0.0632 .0634 0.0633 .0635 0.0634 .0636 0.0635 .0637 0.0636 .0638 0.0637 .0639 0.0638 .0640 0.0639 .0641 0.0640 .0642 0.0641 .0643 0.0642 .0644 0.0643 .0645 0.0644 .0646 0.0645 .0647 0.0646 .0648 0.0647 .0649 0.0648 .0650 0.0649 .0651 0.0650 .0652 0.0651 .0653 0.0652 .0654 0.0653 .0655 0.0654 .0656 0.0655 .0657 0.0656 .0658 0.0657 .0659 0.0658 .0660 0.0659 .0661 0.0660 .0662 0.0661 .0663 0.0662 .0664 0.0663 .0665 0.0664 .0666 0.0665 .0667 0.0666 .0668 0.0667 .0669 0.0668 .0670 0.0669 .0671 0.0670 .0672 0.0671 .0673 0.0672 .0674 0.0673 .0675 0.0674 .0676 0.0675 .0677 0.0676 .0678 0.0677 .0679 0.0678 .0680 0.0679 .0681 0.0680 .0682 0.0681 .0683 0.0682 .0684 0.0683 .0685 0.0684 .0686 0.0685 .0687 0.0686 .0688 0.0687 .0689 0.0688 .0690 0.0689 .0691 0.0690 .0692 0.0691 .0693 0.0692 .0694 0.0693 .0695 0.0694 .0696 0.0695 .0697 0.0696 .0698 0.0697 .0699 0.0698 .0700 0.0699 .0701 0.0700 .0702 0.0701 .0703 0.0702 .0704 0.0703 .0705 0.0704 .0706 0.0705 .0707 0.0706 .0708 0.0707 .0709 0.0708 .0710 0.0709 .0711 0.0710 .0712 0.0711 .0713 0.0712 .0714 0.0713 .0715 0.0714 .0716 0.0715 .0717 0.0716 .0718 0.0717 .0719 0.0718 .0720 0.0719 .0721 0.0720 .0722 0.0721 .0723 0.0722 .0724 0.0723 .0725 0.0724 					



SIZE  
**B**

DRAWING  
INTRO-22

REV.  
1  
OF  
1

PROPRIETARY INFORMATION

INFORMATION CONTAINED HEREIN IS THE PROPERTY OF HURCO MANUFACTURING COMPANY, INC. NO REPRODUCTION OR DISCLOSURE OF THIS INFORMATION SHALL BE MADE BY THE RECIPIENT TO ANY OTHER PERSON OR ORGANIZATION WITHOUT THE PRIOR WRITTEN CONSENT OF HURCO MANUFACTURING COMPANY, INC.

TOOL LIST  
3/16 END MILL

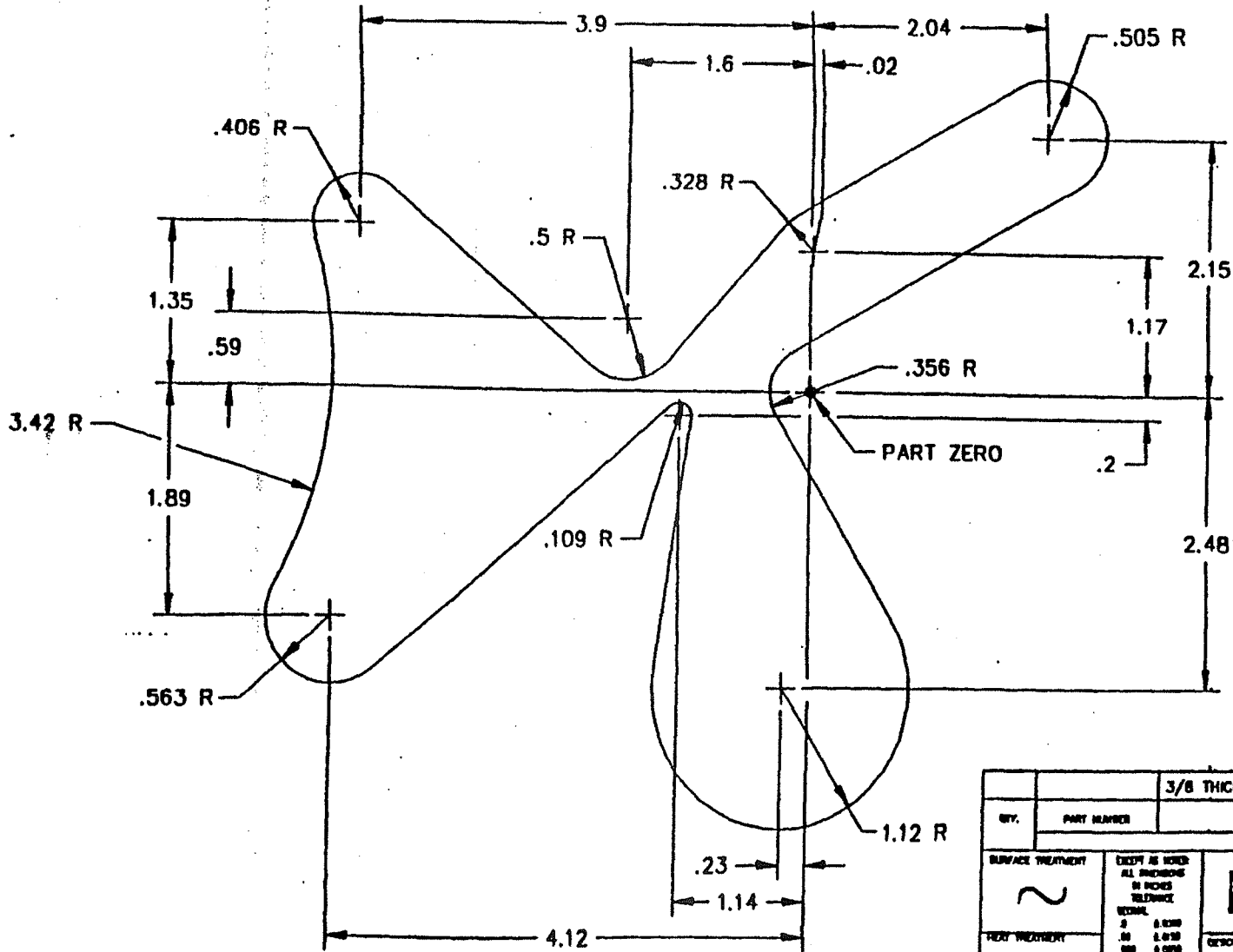

		3/8 THICK 1045 CRS					
QTY.	PART NUMBER	ITEM DESCRIPTION		ITEM			
PARTS LIST							
SURFACE TREATMENT	CHECK IF NEEDED ALL DIMENSIONS IN INCHES TOLERANCE DECIMAL .0 .0000 .01 .0010 .02 .0020 .03 .0030 .04 .0040 .05 .0050 .06 .0060 .07 .0070 .08 .0080 .09 .0090 .10 .0100 .12 .0120 .15 .0150 .20 .0200 .25 .0250 .30 .0300 .40 .0400 .50 .0500 .60 .0600 .75 .0750 .100 .1000 .125 .1250 .150 .1500 .200 .2000 .250 .2500 .300 .3000 .400 .4000 .500 .5000 .600 .6000 .750 .7500 .1000 .10000 .1250 .12500 .1500 .15000 .2000 .20000 .2500 .25000 .3000 .30000 .4000 .40000 .5000 .50000 .6000 .60000 .7500 .75000 .10000 .100000 .12500 .125000 .15000 .150000 .20000 .200000 .25000 .250000 .30000 .300000 .40000 .400000 .50000 .500000 .60000 .600000 .75000 .750000	HURCO HURCO MANUFACTURING COMPANY, INC. INDIANAPOLIS, IN U.S.A.					
TEXT TREATMENT	CHECK IF NEEDED ALL DIMENSIONS IN INCHES TOLERANCE DECIMAL .0 .0000 .01 .0010 .02 .0020 .03 .0030 .04 .0040 .05 .0050 .06 .0060 .07 .0070 .08 .0080 .09 .0090 .10 .0100 .12 .0120 .15 .0150 .20 .0200 .25 .0250 .30 .0300 .40 .0400 .50 .0500 .60 .0600 .75 .0750 .100 .1000 .125 .1250 .150 .1500 .200 .2000 .250 .2500 .300 .3000 .400 .4000 .500 .5000 .600 .6000 .750 .7500 .1000 .10000 .1250 .12500 .1500 .15000 .2000 .20000 .2500 .25000 .3000 .30000 .4000 .40000 .5000 .50000 .6000 .60000 .7500 .75000 .10000 .100000 .12500 .125000 .15000 .150000 .20000 .200000 .25000 .250000 .30000 .300000 .40000 .400000 .50000 .500000 .60000 .600000 .75000 .750000	DESCRIPTION <b>CAM, HIGH SPEED</b>					
FIRST USED ON	THIRD ANGLE PROJECTION	SCALE 1=1 UNIT OF MEAS. EA.	DATE 6-4-83	CHECKED R.HALL	DATE 6-4-83	APPROVED GAW	DATE 8-4-83
M-8		SIZE <b>B</b>	DRAWING INTRO-22		REV. 1 OF 1		

CN  
I22

DRAWING	REV.
B	1
INTRO-23	1

PROPRIETARY INFORMATION  
 INFORMATION CONTAINED HEREIN IS THE PROPERTY OF HUNCO MANUFACTURING COMPANY, INC. NO REPRODUCTION OR  
 DISCLOSURE OF THIS INFORMATION SHALL BE MADE BY THE RECIPIENT TO ANY OTHER PERSON OR ORGANIZATION WITHOUT  
 THE PRIOR WRITTEN CONSENT OF HUNCO MANUFACTURING COMPANY, INC.

TOOL LIST  
 5/8 END MILL

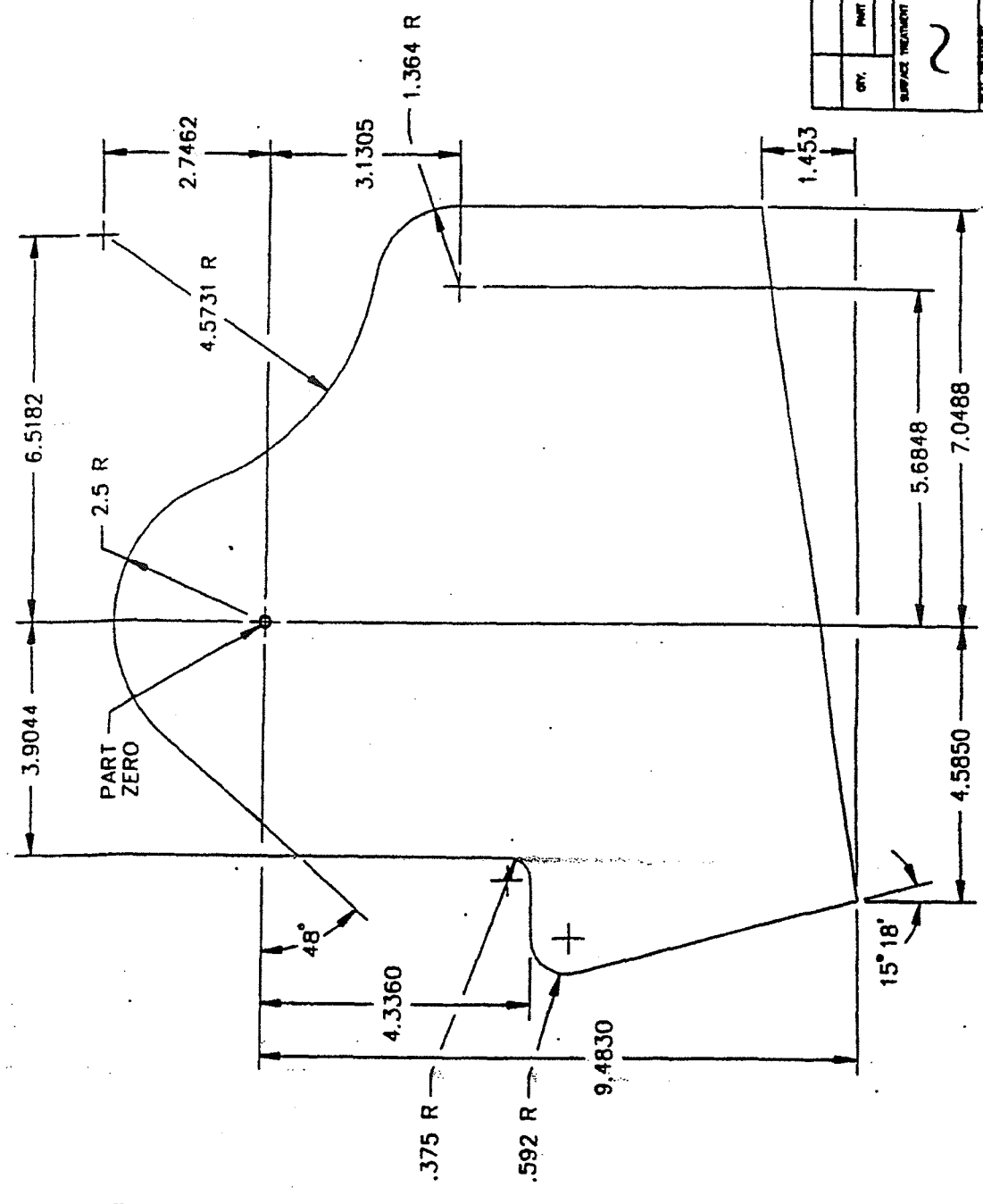

CN  
 I23

QTY.	PART NUMBER	ITEM DESCRIPTION	REV.
		5/8 X 11.983 X 12.8582 1018 HRS	
PARTS LIST			
HUNCO MANUFACTURING COMPANY, INC. HUNCO INDIANAPOLIS, IN U.S.A.			
DESCRIPTION CAM, LOW SPEED			
DATE	BY	DATE	APPROVED
8-8-93	R.HALL	8-8-93	CAW
DATE 8-8-93		DATE 8-8-93	DATE 8-8-93
SIZE B		INTRO-23	
1:2 UNIT OF WOOD EA.		1 1	

TOOL LIST

1/8 CENTER DRILL  
3/8 DRILL

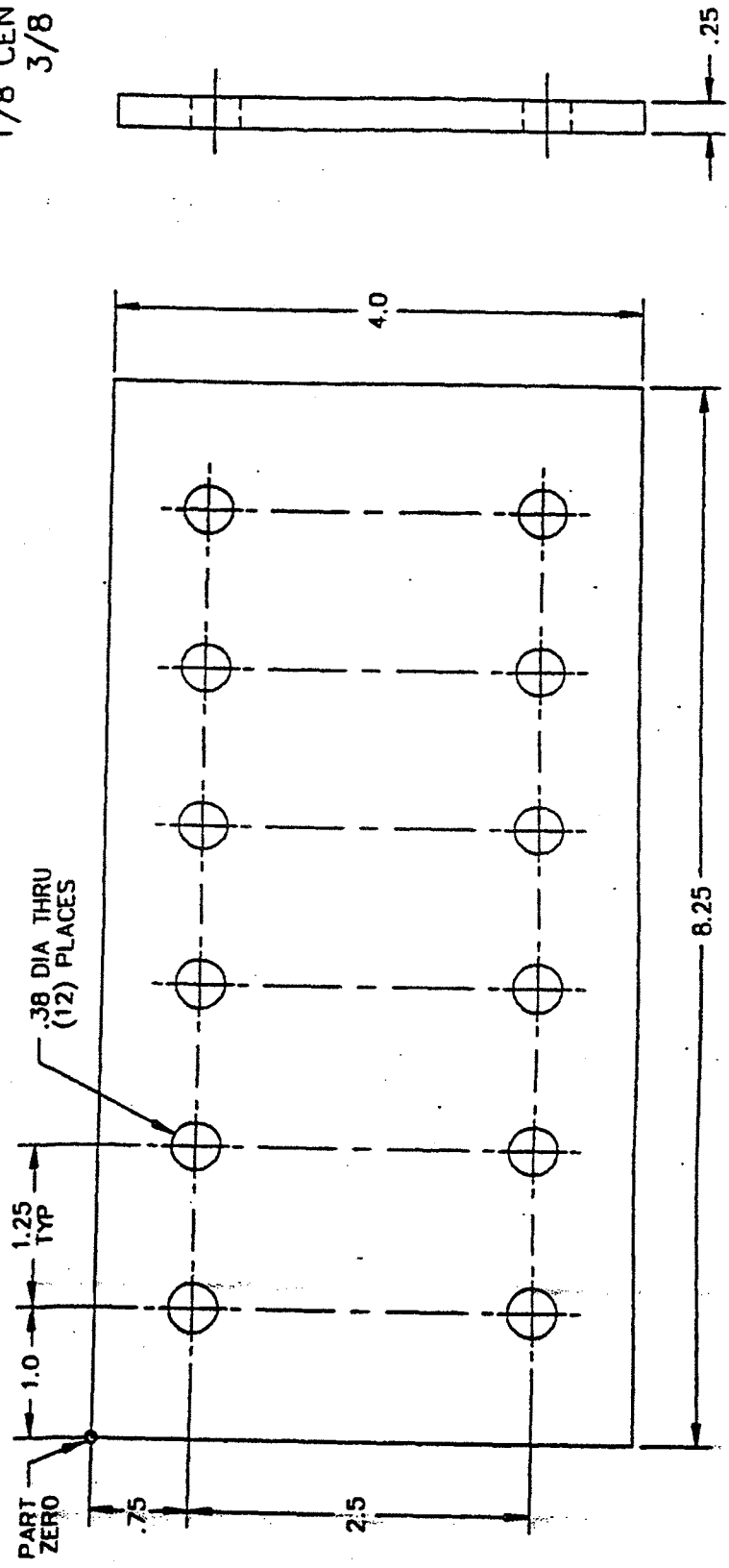

REV: 1/1  
 PROPRIETARY INFORMATION  
 INFORMATION CONTAINED HEREIN IS THE PROPERTY OF HUNCO MANUFACTURING COMPANY, INC. NO REPRODUCTION OR  
 DISSEMINATION OF THIS INFORMATION SHALL BE MADE BY THE RECIPIENT OR ANY OTHER PERSON WITHOUT THE  
 EXPRESS WRITTEN CONSENT OF HUNCO MANUFACTURING COMPANY, INC.

REV: 1/1  
 INTRO-24  
 B

REV:	1/1	1/4 X 4.0 X 8.25 ASTM A36 CRIS	FROM DESCRIPTION	REV:	
PART NUMBER		PARTS LIST			
DESCRIPTION	PLATE, SPACER	HUNCO MANUFACTURING COMPANY, INC. INDIANAPOLIS, IN U.S.A.		DATE	8-8-83
DATE	8-8-83	DATE	8-8-83	APPROVED	GAW
BY	GLH	BY	R.HALL	DATE	8-8-83
SCALE	1 = 1	SCALE		BY	
PRODUCTION	EA	PRODUCTION	B	INTRO-24	
TEST USED ON	M-8				

CN  
I24

REV. 1  
 1 of 1  
 DRAWING  
 B INTRO-29

PROPRIETARY INFORMATION  
 INFORMATION CONTAINED HEREON IS THE PROPERTY OF HURCO MANUFACTURING COMPANY, INC. AND REPRODUCTION OR  
 DISCLOSURE OF THIS INFORMATION SHALL BE MADE BY THE RECIPIENT TO ANY OTHER PERSON OR ORGANIZATION WITHOUT  
 THE PRIOR WRITTEN CONSENT OF HURCO MANUFACTURING COMPANY, INC.

TOOL LIST  
 3/4 END MILL

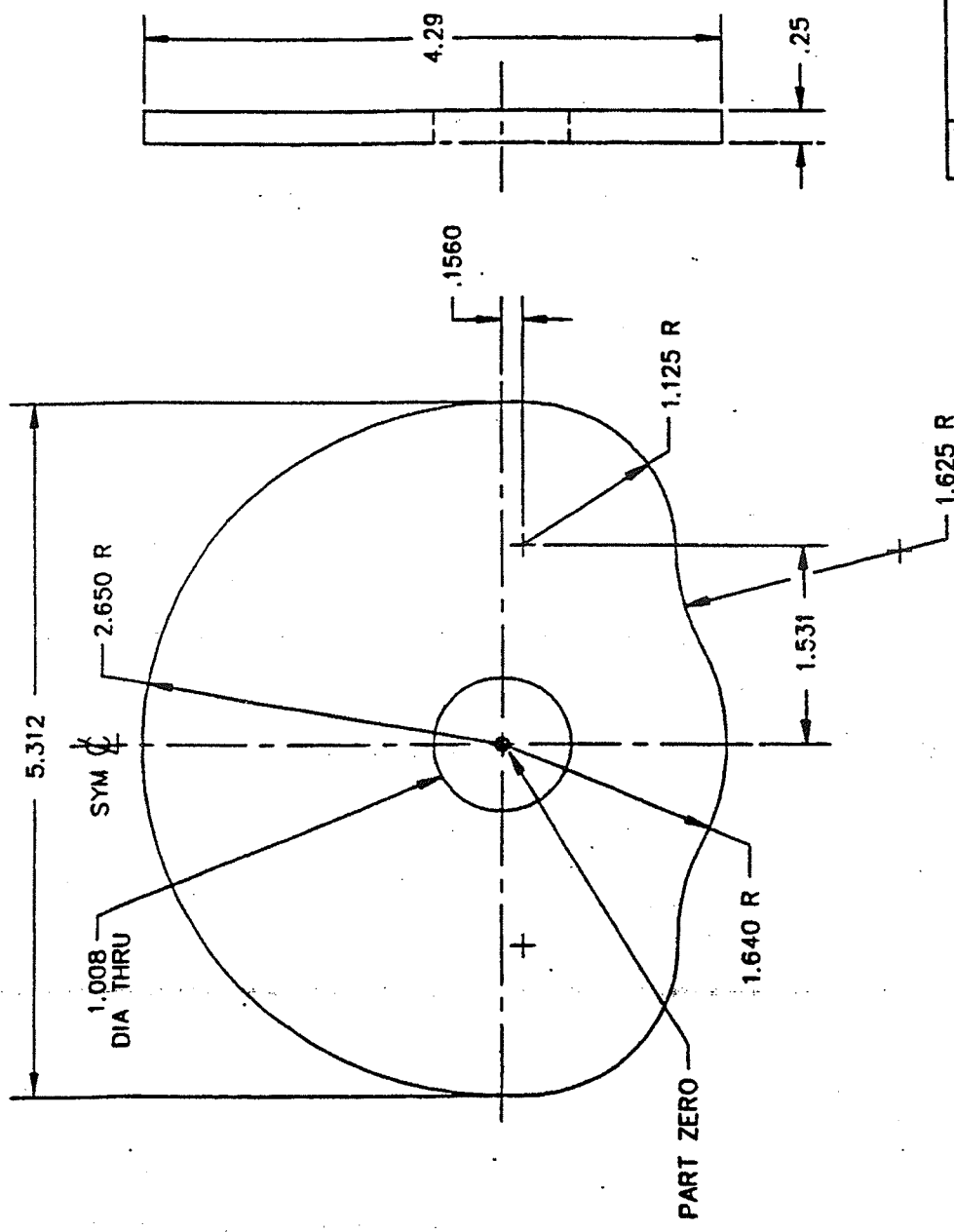

SURFACE FINISH		1/4 X 4.29 X 5.312 CLASS 40 CAST IRON	
~	~	HURCO MANUFACTURING COMPANY, INC. INDIANAPOLIS, IN U.S.A.	
~	~	DESCRIPTION PLATE, HIGH SPEED CAM	
~	~	DATE 8-10-83	DATE 8-10-83
~	~	BY R.HALL	BY GAW
~	~	SIZE B	QTY 1
~	~	PRODUCTION EA	INTRO-29
~	~	DATE 8-10-83	DATE 8-10-83
~	~	BY GAW	BY GAW
~	~	SIZE B	QTY 1
~	~	PRODUCTION EA	INTRO-29

CN  
 T29

SITE  
B

INTRO-31

PROPRIETARY INFORMATION  
 INFORMATION CONTAINED HEREIN IS THE PROPERTY OF MUNCO MANUFACTURING COMPANY, INC. NO REPRODUCTION OR  
 DISCLOSURE OF THIS INFORMATION SHALL BE MADE IN ANY MANNER WITHOUT THE WRITTEN CONSENT OF MUNCO MANUFACTURING COMPANY, INC.

TOOL LIST

3/4 END MILL

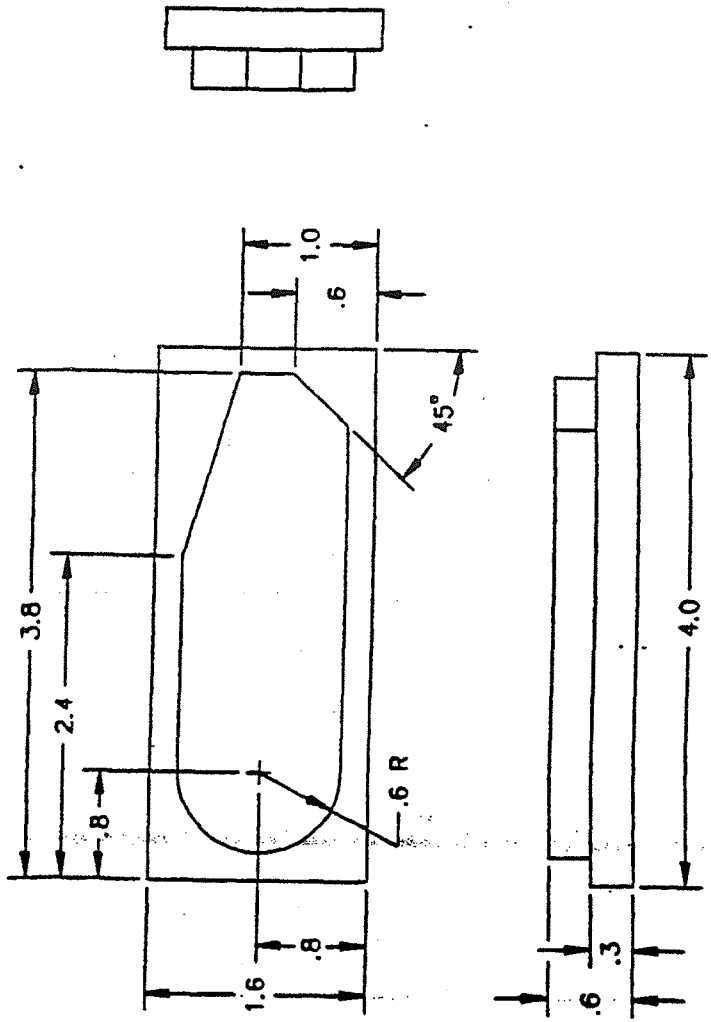

QTY.	PART NUMBER	ITEM DESCRIPTION	REV.
		.6 X 1.6 X 4.0 3003-F ALUMINUM	
MUNCO			
MUNCO MANUFACTURING COMPANY, INC. INDIANAPOLIS, IN U.S.A.			
MATERIAL			
LOCK, SLIDE			
DATE	BY	DATE	BY
6-10-93	R.HALL	6-10-93	GAW
DESCRIPTION		DATE	BY
GLH		6-10-93	GAW
1 = 1		B	
INTRO-31		INTRO-31	
M-8		EA.	

CN  
I 31

SIZE  
**B**

INTRO-32

REV.  
1  
OF  
1

PROPRIETARY INFORMATION

INFORMATION CONTAINED HEREIN IS THE PROPERTY OF HURCO MANUFACTURING COMPANY, INC. NO REPRODUCTION OR DISCLOSURE OF THIS INFORMATION SHALL BE MADE BY ANY PERSON IN ANY MANNER WITHOUT THE PRIOR WRITTEN CONSENT OF HURCO MANUFACTURING COMPANY, INC.

TOOL LIST  
3/4 END MILL

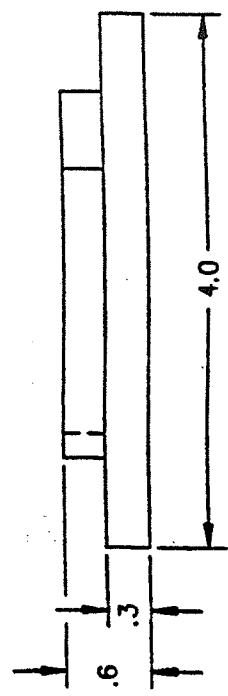
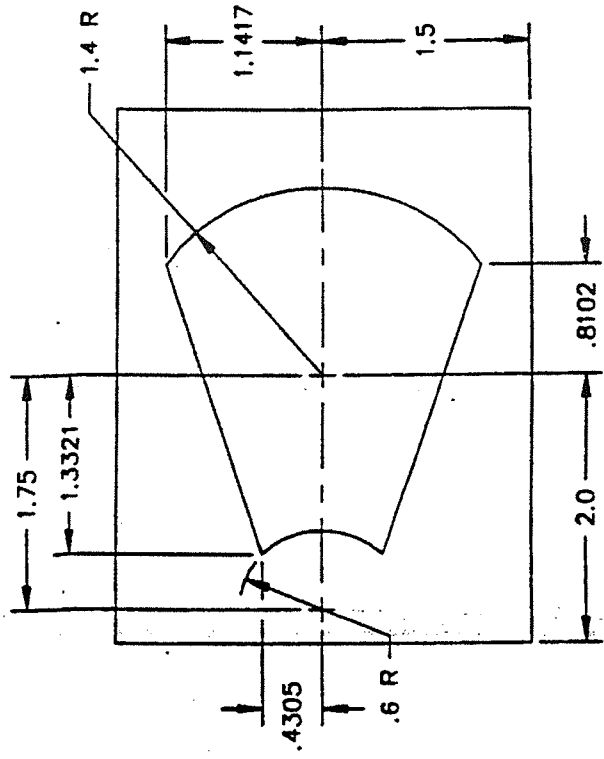

QTY.	PART NUMBER	ITEM DESCRIPTION	REV.		
		.6 X 3.0 X 4.0 1045 CRS			
PARTS LIST					
SURFACE TREATMENT		EXCEPT AS NOTED ALL DIMENSIONS IN THIS DRAWING UNLESS OTHERWISE SPECIFIED ARE IN INCHES AND DECIMALS HEREOF TOLERANCES UNLESS SPECIFIED ARE AS FOLLOWS FRACTIONS DECIMALS MILLIMETERS HOLE DIA. SHAFT DIA. TYPICAL PROTECTIONS	HURCO MANUFACTURING COMPANY, INC. INDIANAPOLIS, IN U.S.A.		
TEMP. TREATMENT		GLH	DATE	APPROVED	DATE
FIRST USED ON		9-18-93	R. HALL	9-18-93	9-18-93
M-8		SCALE	INTRO-32	REV.	REV.
		1:1	B	1	1
		EA.			

CN  
I32